

BEST 130

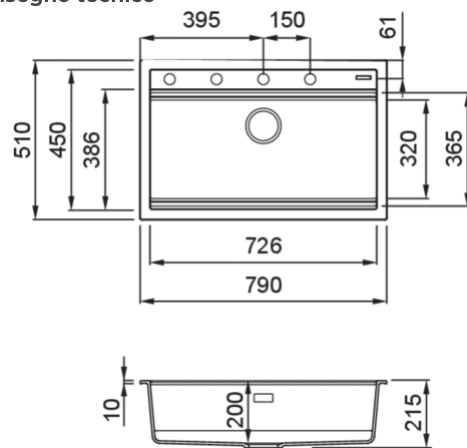

Disegno tecnico



CARATTERISTICHE PRODOTTO

Descrizione	Lavello 1 vasca
Modello	BEST 130
Base (mm)	800
Installazioni	Sopratop
Dimensioni (mm)	790 x 510
Foro da Incasso (mm)	770 x 480
Numero Vasche	1
Profondità Vasca (mm)	200



DATI LOGISTICI

Peso Lordo (kg)	18,85
Peso Netto (kg)	13,00
Dimensioni Imballo (kg)	870 x 575 x 300
Volume Imballo (kg)	0,150

CARATTERISTICHE IMBALLO

Imballo	Cartone e polietilene
Corredi	Sifone salvaspazio, piletta Flow Pro integrata, troppopieno rettangolare e ganci. Corredo del lavello Bundle: Colander, Drainer Flex, sifone salvaspazio, piletta Flow Pro integrata, troppopieno rettangolare e ganci.

KERATEK



LKB13086 K86
8032557027140



LKB13093 K93
8032557027157



LKB13095 K95
8032557027164



LKB13096 K96
8032557027171



LKB13097 K97
8032557027188



LKB13099 K99
8032557027195

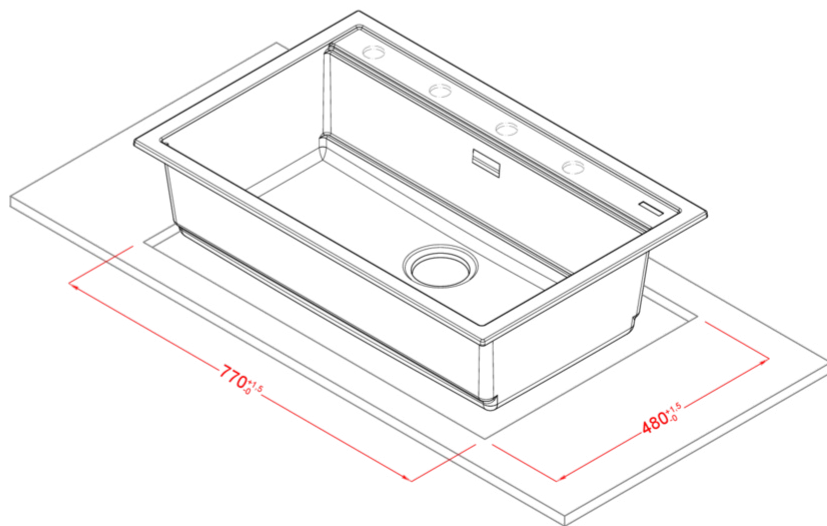
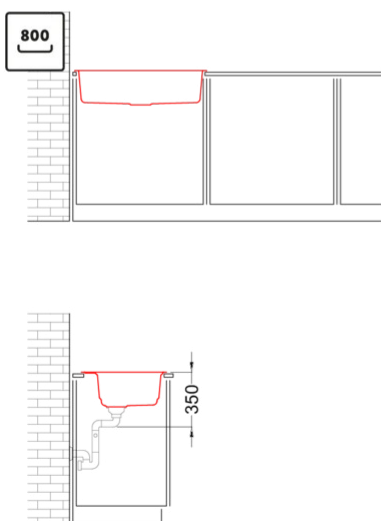
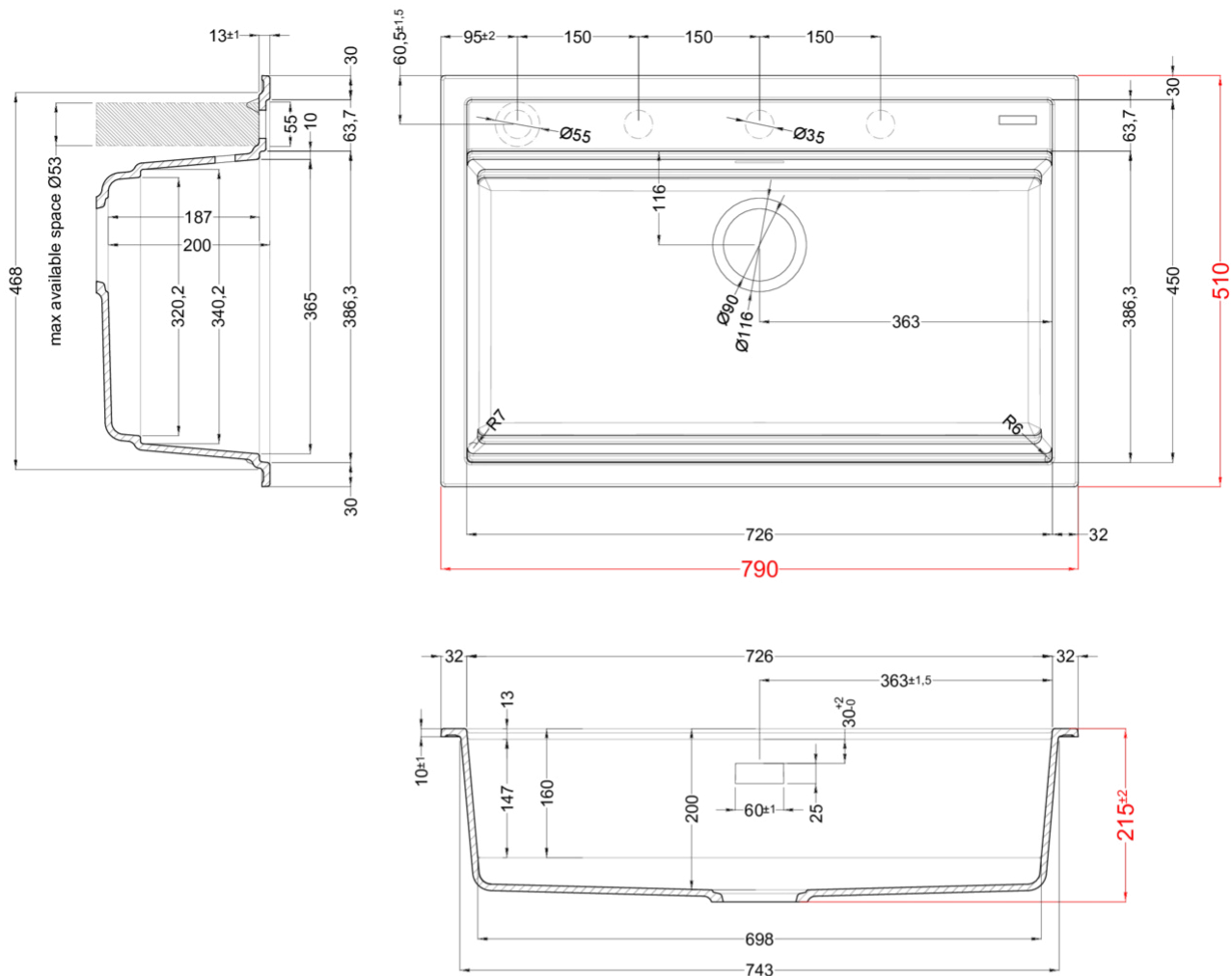

BEST 130

general tolerances where not expressly communicated ±0.2%
connection dimensions according to UNI EN 695

