

## ZEN 102

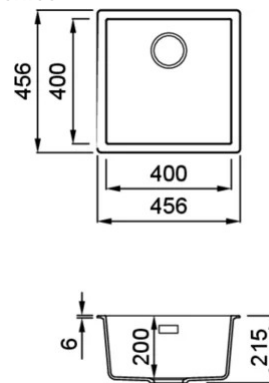

### Disegno tecnico



### CARATTERISTICHE PRODOTTO

<b>Descrizione</b>	Lavello 1 vasca
<b>Modello</b>	ZEN 102
<b>Base (mm)</b>	450     500 se inizio composizione (Sopratop), 500 (Sottotop)
<b>Installazioni</b>	Sopratop, Sottotop
<b>Dimensioni (mm)</b>	456 x 456
<b>Foro da Incasso (mm)</b>	445 x 445 R5 (Standard), 400 x 400 R10 (Sottotop)
<b>Numero Vasche</b>	1
<b>Profondità Vasca (mm)</b>	200



### DATI LOGISTICI

<b>Peso Lordo (kg)</b>	11,51
<b>Peso Netto (kg)</b>	6,42
<b>Dimensioni Imballo (kg)</b>	575 x 575 x 300
<b>Volume Imballo (kg)</b>	0,099

### CARATTERISTICHE IMBALLO

<b>Imballo</b>	Cartone e polietilene
<b>Corredi</b>	Sifone salvaspazio, piletta Flow Pro integrata, troppopieno rettangolare, ganci e kit montaggio Sottotop.

## KERATEK



LKZ10286 K86  
8031873027780



LKZ10293 K93  
8031873027797

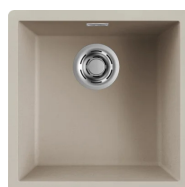

LKZ10295 K95  
8031873027803



LKZ10296 K96  
8031873027810



LKZ10297 K97  
8031873027827



LKZ10299 K99  
8031873027834

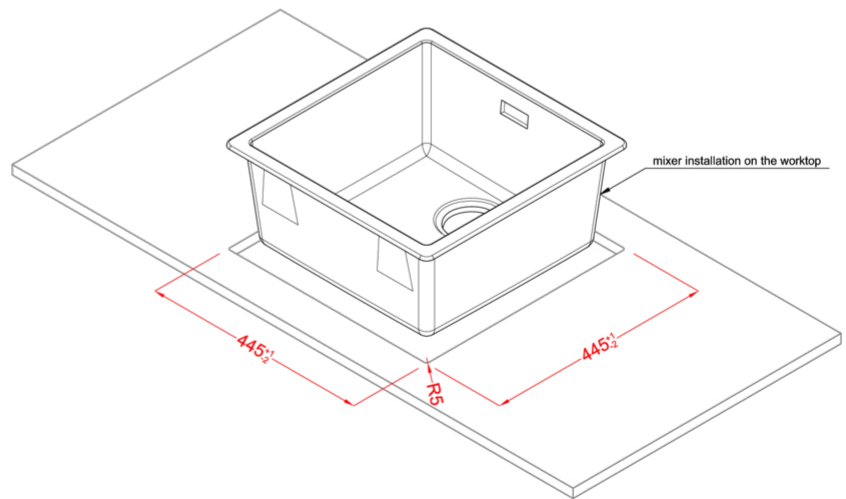
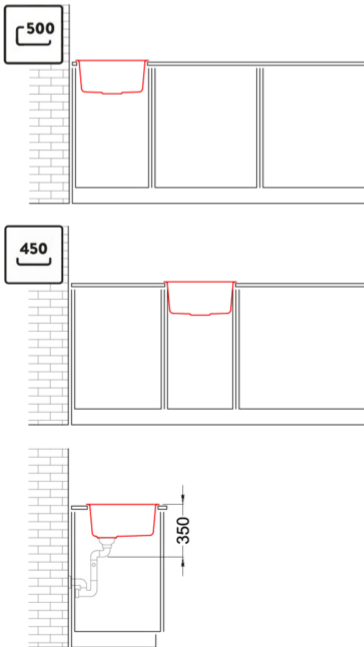
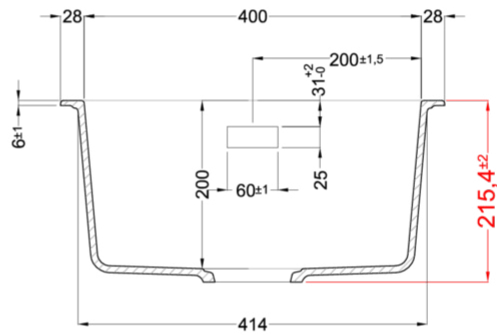
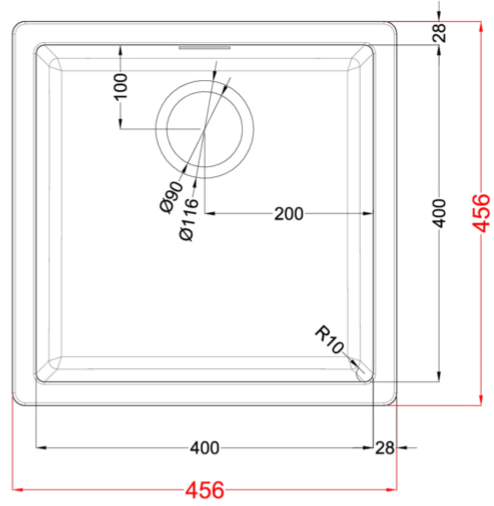
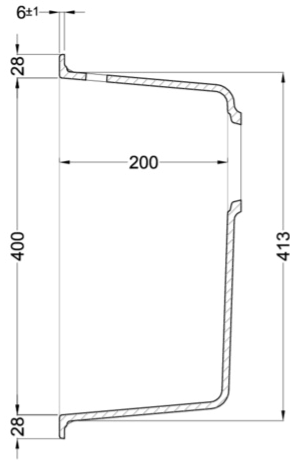

## ZEN 102

general tolerances where not expressly communicated  $\pm 0.2\%$   
connection dimensions according to UNI EN 695

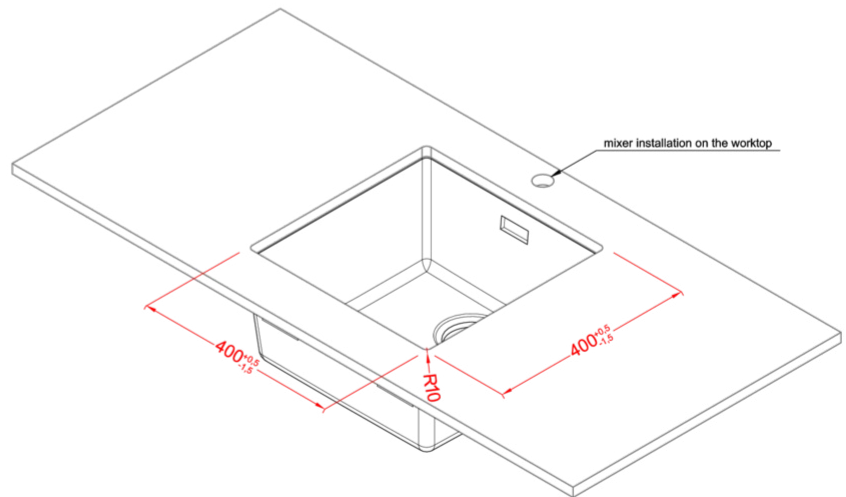
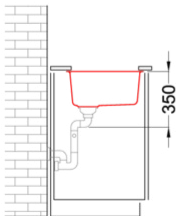
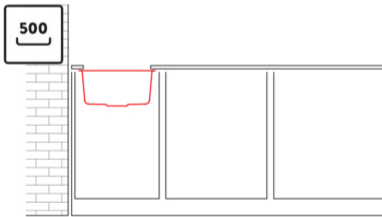
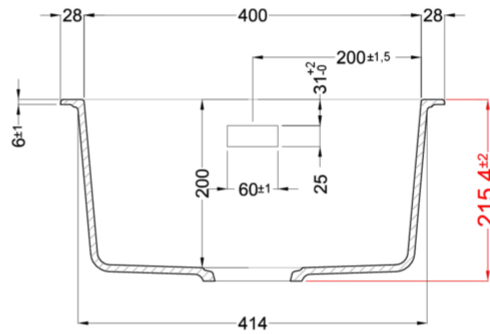
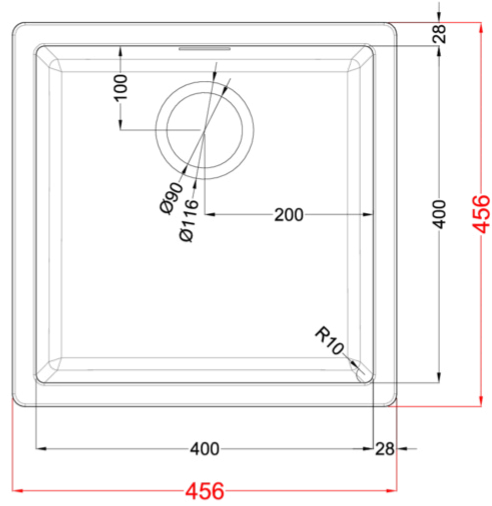
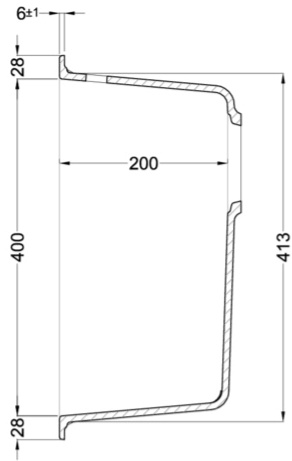

## ZEN 102 UNDERMOUNT

general tolerances where not expressly communicated  $\pm 0.2\%$   
connection dimensions according to UNI EN 695



