

BEST 360 BUNDLE

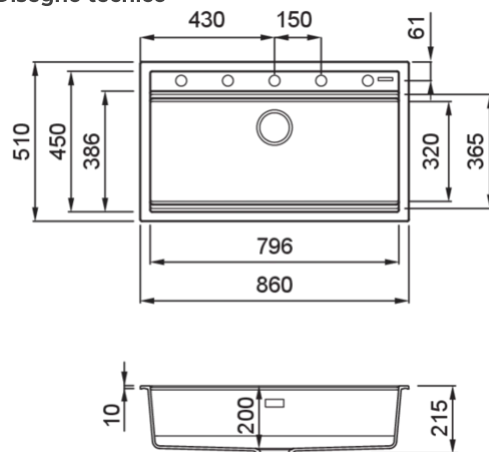

Disegno tecnico



CARATTERISTICHE PRODOTTO

Descrizione	Lavello 1 vasca con Flex Drainer e colander inclusi
Modello	BEST 360 BUNDLE
Base (mm)	900
Installazioni	Sopratop
Dimensioni (mm)	860 x 510
Foro da Incasso (mm)	840 x 480
Numero Vasche	1
Profondità Vasca (mm)	200

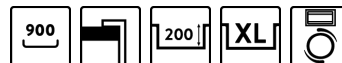

DATI LOGISTICI

Dimensioni Imballo (kg)	940 x 575 x 300
Volume Imballo (kg)	0,162

CARATTERISTICHE IMBALLO

Imballo	Cartone e polietilene
Corredi	Sifone salvaspazio, piletta Flow Pro integrata, troppopieno rettangolare e ganci. Corredo del lavello Bundle: Colander, Drainer Flex, sifone salvaspazio, piletta Flow Pro integrata, troppopieno rettangolare e ganci.

KERATEK



LKB36086K2 K86
8032557027454



LKB36093K2 K93
8032557027461



LKB36095K2 K95
8032557027478



LKB36096K2 K96
8032557027485



LKB36097K2 K97
8032557027492



LKB36099K2 K99
8032557027508

GRANITEK

METAL



LMB36073K2 M73
8031873117665



LMB36079K2 M79
8031873117689

GRANITEK

MATT



LGB36040K2 G40
8031873069810



LGB36043K2 G43
8031873069827



LGB36048K2 G48
8031873069834



LGB36068K2 G68
8031873069872



LGB36078K2 G78
8032557066903

GRANITEK

CLASSIC



LGB36051K2 G51
8031873069841



LGB36059K2 G59
8031873069858



LGB36062K2 G62
8031873069865

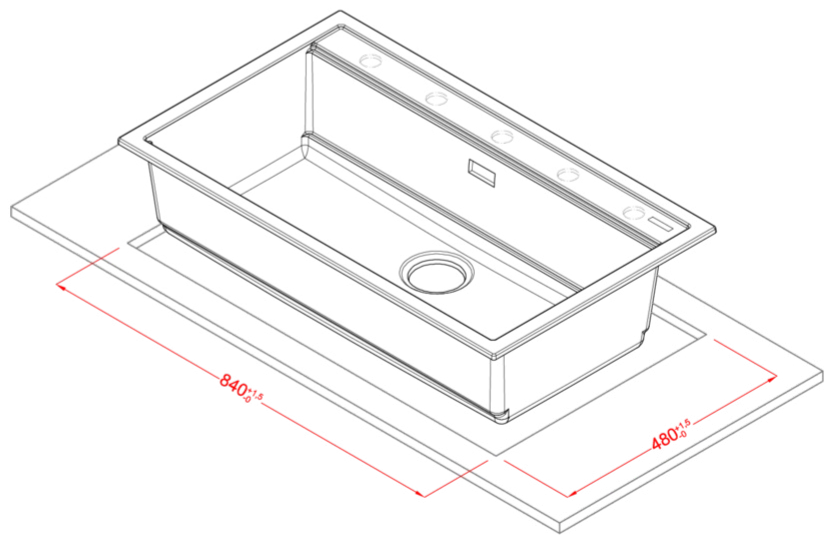
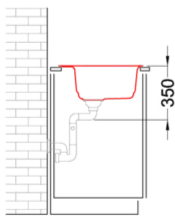
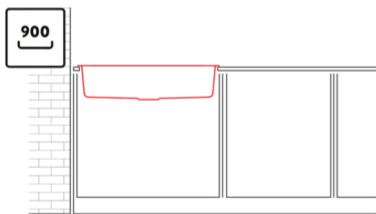
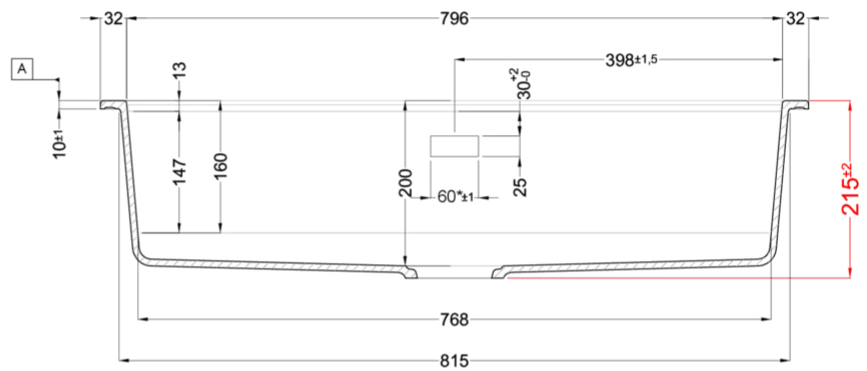
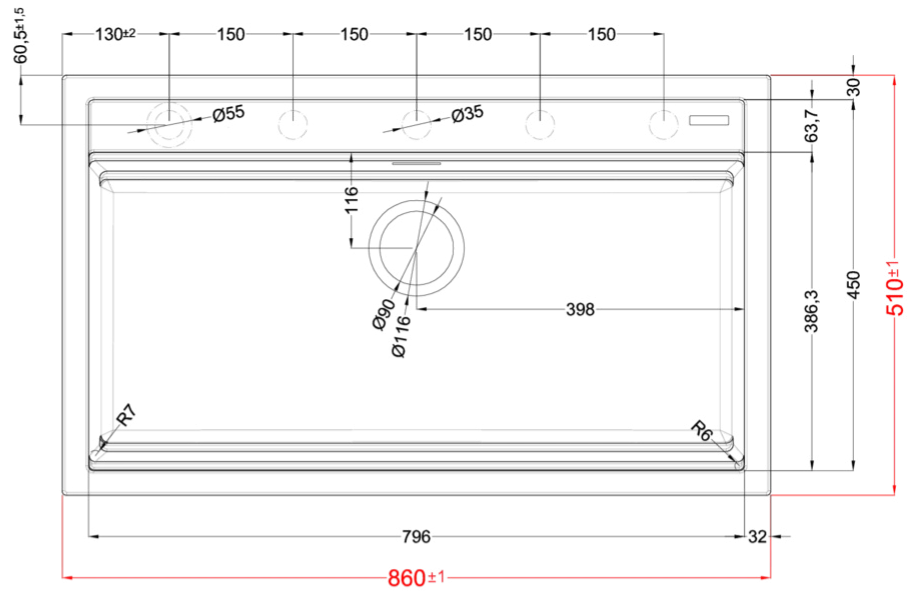
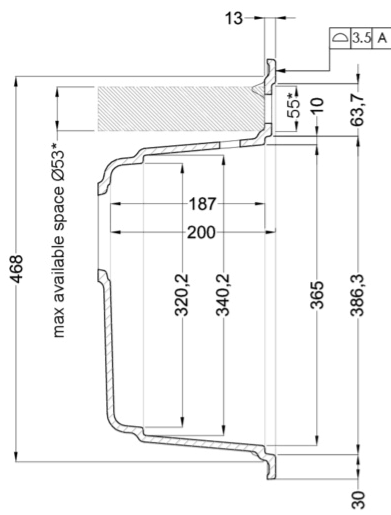

Best 360

general tolerances where not expressly communicated ±1 mm
 connection dimensions according to UNI EN 695
 eventual exceptions are reported with *

elleci