

CHEF



CARATTERISTICHE PRODOTTO

Descrizione	Miscelatore monocomando con canna alta girevole e doccetta doppio getto
Modello	CHEF
Base (mm)	50
Dimensione foro (ømm)	35
Rotazione Canna	360°
Flessibile	Inox 3/8"
Cartuccia (ømm)	35

DATI LOGISTICI

Peso Lordo (kg)	3,24
Peso Netto (kg)	2,48
Dimensioni Imballo (kg)	48,5 x 25 x 9
Volume Imballo (kg)	0,011

CARATTERISTICHE IMBALLO

Imballo	Box in cartone
----------------	----------------

KERATEK



MKKCHE86 K86
8032557561408

Disegno tecnico

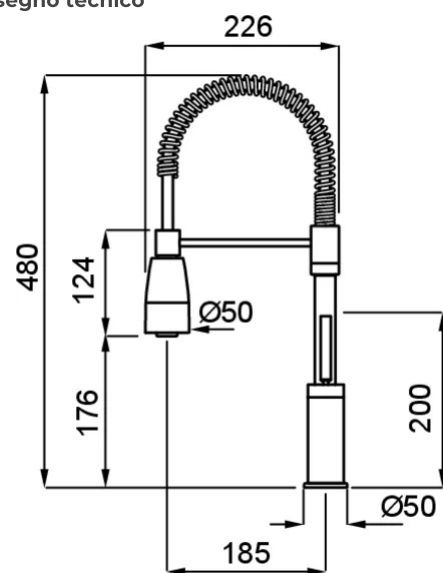

GRANITEK

MATT



MGKCHE40 G40
8031873103231

CROMATO



MIKCHECR CR
8031873650575

