

MASTER 500

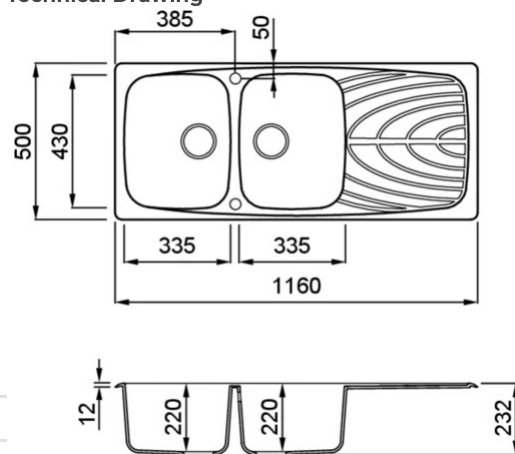

Technical Drawing



0

Description 2-bowl sink with drainer

Model MASTER 500

Base (mm) 800

0 Inset

Dimensions (mm) 1160 x 500

Hole for built-in installation (mm) 1140 x 480

Number of Bowls 2

0

Gross Weight (kg) 23,34

Net Weight (kg) 16,80

Packaging Dimension (kg) 1250 x 575 x 300

0 (kg) 0,216

0

Packaging Cardboard and polyethylene

0 Space-saving siphon, wastes and hooks.



GRANITEK

MATT



LGM50040 G40
8032557043508



LGM50068 G68
8031873056216

GRANITEK

CLASSIC



LGM50051 G51
8031873056049



LGM50059 G59
8031873056124



LGM50062 G62
8031873056155

