

## ATHENA



### CARATTERISTICHE PRODOTTO

<b>Descrizione</b>	Miscelatore monocomando con canna girevole
<b>Modello</b>	ATHENA
<b>Base (mm)</b>	48
<b>Dimensione foro (ømm)</b>	35
<b>Rotazione Canna</b>	360°
<b>Flessibile</b>	Inox 3/8"
<b>Cartuccia (ømm)</b>	25

### DATI LOGISTICI

<b>Peso Lordo (kg)</b>	1,95
<b>Peso Netto (kg)</b>	1,56
<b>Dimensioni Imballo (kg)</b>	50 x 30 x 8
<b>Volume Imballo (kg)</b>	0,012

### CARATTERISTICHE IMBALLO

<b>Imballo</b>	Box in cartone
----------------	----------------

### Disegno tecnico

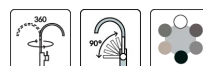
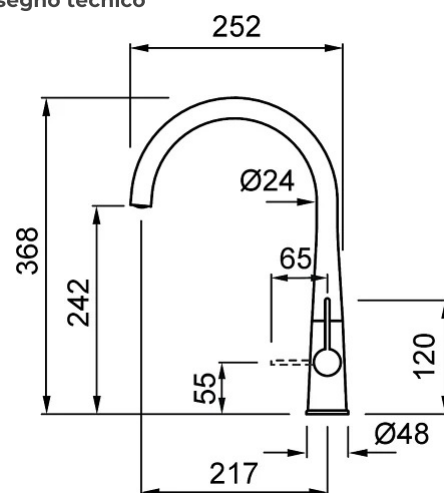

## GRANITEK

### METAL



**MMKATH79** M79  
8031873551070

## GRANITEK

### MATT



**MGKATH40** G40  
8031873101763



**MGKATH43** G43  
8031873102357



**MGKATH48** G48  
8031873102364



**MGKATH68** G68  
8031873101756

**CROMATO**



**MIKATHCR CR**  
8031873651169

