

ATHENA PLUS



FEATURES

Description	Single-lever tap with swivel spout and pull-out sprayer
Model	ATHENA PLUS
Base (mm)	48
(\varnothing mm)	35
	360°
Flexi-hose	Stainless Steel 3/8"
(\varnothing mm)	25

LOGISTIC DATA

Gross Weight (kg)	1,95
Net Weight (kg)	1,56
Packaging Volume (kg)	0,012

PACKAGING FEATURES

Packaging	Cardboard box
------------------	---------------

Technical Drawing

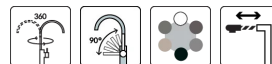
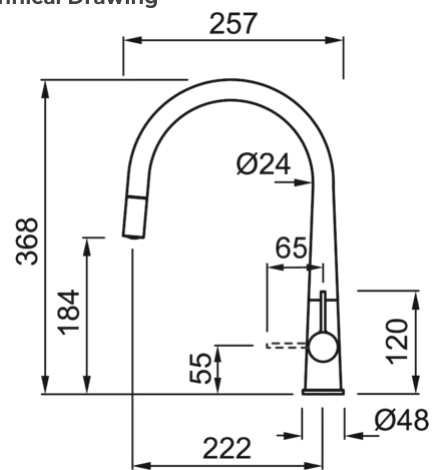

GRANITEK

METAL



MMKATP79 M79
8031873551582

GRANITEK

MATT



MGKATP40 G40
8031873104467



MGKATP43 G43
8031873104481



MGKATP48 G48
8031873104474



MGKATP68 G68
8031873104498

CROMATO



MIKATPCR CR
8031873651824