

ATHENA PLUS



CARATTERISTICHE PRODOTTO

Descrizione	Miscelatore monocomando con canna girevole e doccetta estraibile
Modello	ATHENA PLUS
Base (mm)	48
Dimensione foro (ømm)	35
Rotazione Canna	360°
Flessibile	Inox 3/8"
Cartuccia (ømm)	25

DATI LOGISTICI

Peso Lordo (kg)	1,95
Peso Netto (kg)	1,56
Volume Imballo (kg)	0,012

CARATTERISTICHE IMBALLO

Imballo	Box in cartone
----------------	----------------

Disegno tecnico

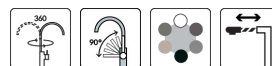
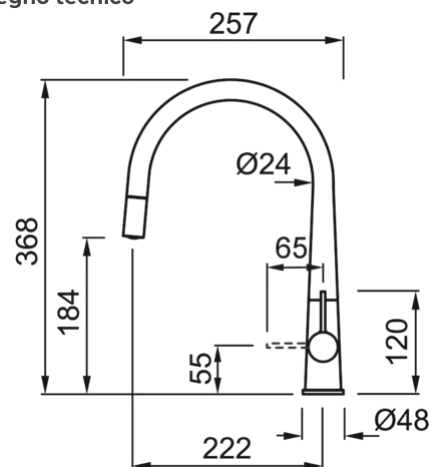

GRANITEK

METAL



MMKATP79 M79
8031873551582

GRANITEK

MATT



MGKATP40 G40
8031873104467



MGKATP43 G43
8031873104481



MGKATP48 G48
8031873104474



MGKATP68 G68
8031873104498

CROMATO



MIKATPCR CR
8031873651824