

RENO

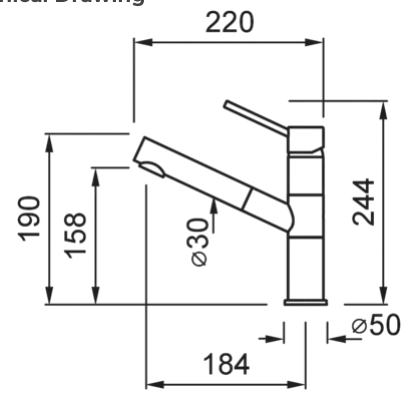

Technical Drawing



FEATURES

Description	Single-lever tap with swivel spout and pull-out sprayer
Model	RENO
Base (mm)	50
(\varnothing mm)	35
	360°
Flexi-hose	Stainless Steel 3/8"
(\varnothing mm)	35

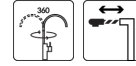

LOGISTIC DATA

Gross Weight (kg)	2,14
Net Weight (kg)	1,84
Packaging Dimension (kg)	48,5 x 25 x 9
Packaging Volume (kg)	0,011

PACKAGING FEATURES

Packaging	Cardboard box
------------------	---------------

KERATEK



MKKREN86 K86
8032557560302



MKKREN96 K96
8032557560319

GRANITEK

MATT



MGKREN40 G40
8031873101879



MGKREN43 G43
8031873101077



MGKREN48 G48
8031873102111



MGKREN68 G68
8031873102203

GRANITEK

CLASSIC



MGKREN59 G59
8031873100650

CROMATO



MIKRENCR CR
8031873650032

